

# PERFORMANCE ALLOYS®

...World Wide Distributor Beryllium-Free CopperAlloys...  
Manufacturer of Standard & Custom Mold Components

N116 W18515 Morse Dr.  
Germantown, WI 53022  
(262) 255-6662  
Fax (262) 255-3655  
**1-800-272-3031**

**E MAIL: nobecu@aol.com WEB SITE: www.performancealloys.net**

**Providing Industry with Technology, Products and Services Since 1987**

Our primary focus is to help you improve part quality, mold productivity and overall performance with our Beryllium-Free copper alloy materials & products.

**Performance Alloys® is Proud to Introduce**

**Our NEW MoldStar® Alloys & Precision Machining Capabilities**

**MoldStar® 90 \* in PLATE & Round Bar\***  
**MoldStar® 150 \*(formerly PAS or Ampco 940)\***  
**MoldStar® 18, 21 & 22 Aluminum Bronze Alloys**  
**Performance Core Pins®**  
**Performance Sprue Bushings®**



**Performance Mold Products®**

**ATTENTION:** We also offer molders and moldmakers the option of finish machined components at competitive prices, with on time deliveries and unmatched quality. We are proud of the fact that consistently, year after year, our customers rate us at the highest levels for our Quality, Service, Competitive Prices and ON TIME DELIVERIES.

**Feel free to request a quote for your CUSTOM Components**

***ALWAYS CHECK OUR WEBSITE!***

**www.performancealloys.net, for the LATEST Product Information & Technical UPDATES**

***We personally invite you to experience our exceptional level of quality and service.***

## CONTENTS

- COVER PAGE
- INDEX
- GENERAL INFORMATION, POLICIES and ACKNOWLEDGEMENTS
- PRODUCTS
- MoldStar MATERIAL RECOMMENDATIONS
- POPULAR MATERIAL COMPARISONS

### MoldStar MATERIAL FOR PLASTIC FORMING AREAS

- MoldStar 90 APPLICATION INFORMATION
- MoldStar 90 AVAILABLE PLATE and BAR SIZES
- MoldStar 150 APPLICATION INFORMATION
- MoldStar 150 AVAILABLE PLATE and BAR SIZES

### HOW WE STACK UP AGAINST THE COMPETITION

#### MoldStar BRONZES FOR WEAR APPLICATIONS

- MoldStar 18 APPLICATION INFORMATION
- MoldStar 18 SOLID ROUND BAR SIZES
- MoldStar 18 RECTANGULAR SIZES
- MoldStar 18 TUBE SIZES
- MoldStar 21 APPLICATION INFORMATION
- MoldStar 21 SOLID ROUND BAR SIZES
- MoldStar 21 RECTANGULAR SIZES
- MoldStar 22 APPLICATION INFORMATION and SIZES

#### HIGH CONDUCTIVITY COPPER ALLOY CORE PINS

- PERFORMANCE CORE PIN APPLICATION INFORMATION
- PERFORMANCE CORE PIN SPECIFICATION and SIZES
- PERFORMANCE CORE PIN PRICING

#### HIGH CONDUCTIVITY SPRUE BUSHINGS

- PERFORMANCE SPRUE BUSHING APPLICATION INFORMATION
- PERFORMANCE SPRUE BUSHING SPECIFICATIONS and SIZES
- PERFORMANCE SPRUE BUSHINGS for ABRASIVE RESINS<sup>5</sup>

#### ORDER FORMS AND PRINT MASTERS

- MoldStar MATERIAL ORDER FORMS
- CUSTOM COMPONENT ORDER INFORMATION
- STANDARD STRAIGHT EJECTOR PIN SIZES
- STANDARD STEP EJECTOR PIN SIZES
- CUSTOM EJECTOR SLEEVE PRINTS
- CUSTOM STEP PIN PRINTS
- CUSTOM STRAIGHT PIN PRINTS

#### MISC. TECHNICAL DATA

- SAWING INFORMATION
- MACHINING INFORMATION
- PLATING INFORMATION

#### WELDING INFORMATION

- WELDING GUIDELINES
- MoldStar WELDROD

## **GENERAL CONDITIONS**

While every effort is made to offer stable and competitive pricing, prices are subject to change without notice. Previously quoted prices are subject to the term limits on a specific quotation. Because of circumstance beyond our control, product and supplier changes/substitutions are made from time to time. When such instances occur the material and products will meet at least the minimum published properties as outline in our promotional literature.

## **TERMS**

Net 30 days to established US businesses with acceptable credit history. We may from time to time establish credit limits or require partial or full prepayment before orders are shipped and/or processed. Payment terms for Non US businesses are typically due via wire transfer prior to shipment, or as arranged prior to order placement.

## **DELIVERIES**

Every effort is made to meet quoted ship dates, but may be subject to delays caused by fire, strike or other causes beyond our control. We cannot be responsible for such delays or delays arising from transportation service, nor damage sustained by goods after delivery to carrier.

## **RETURNED GOODS/ORDER CANCELLATIONS**

No goods are returnable without prior approval and prepaid transportation. All returned items are subject to our inspection before credit is allowed/issued. Custom forged or non-standard sizes and shapes may be non-returnable. No goods are returnable later than 30 days after receipt of merchandise. Credit for returned goods will be based on re-saleable condition of returned item. Cancellation of an order after either verbal or written purchase order confirmation is subject to a cancellation/restocking charge. An order cancellation notice must be in writing to us and delivered to our sales office to be considered cancelled. Finish or partially finish machined components are non-returnable unless our work was not to original print specifications..

## **DEFECTIVE MATERIAL**

Every effort is made in manufacturing, inspection and other parts of our processes to insure sound products. Even with our extensive process control and inspection, there can be metallurgical defects that go undiscovered. We deeply regret those situations and will gladly replace any piece or pieces of material that prove to be metallurgically defective. We cannot warrant any material that has been welded, or subjected to heat treatments done by others. Liability for defective material is limited to replacement of that material only.

## **SUBJECT TO CHANGE**

We reserve the right to make changes of any type without notice, obligation or liability.

## **TRADEMARK ACKNOWLEDGMENTS**

*MoldStar* as well as the word *Mold* accompanied by a *Star* symbol, *Performance Core Pins* and *Performance Sprue Bushings* are all Registered Trademarks of Performance Alloys and Services, Inc. *MoldMAX* and *proTHERM* are Registered Trademarks of Brush Wellman Engineered Materials. *MoldMATE* and *Ampco* are Registered Trademarks of Ampco Metal Inc, and *QC-7* is a Registered Trademark of Copper and Brass Sales.

Performance Alloys and Services, Inc.  
Performance Mold Products, Inc.  
N116 W18515 Morse Dr.  
Germantown, Wisconsin 53022  
262-255-6662 or 800-272-3031  
Fax:262-255-3655  
Email: [nobecu@aol.com](mailto:nobecu@aol.com)

WebSite: [www.performancealloys.net](http://www.performancealloys.net)

Always refer to our website for the most current product as well other information

## Products

### QUALITY RAW MATERIALS

#### **MoldStar® 90 & 150 for Cores and Cavities Outperform Competitive Products!**

Our Beryllium-Free Copper Alloys have been proven to be the material of choice for the BEST Performance in Injection & Blow Mold applications Being Beryllium-Free means safe, economical, mechanical and environmental advantages.

*SAFE TODAY, SAFE TOMORROW*

#### **MoldStar® 18, 21 & 22 Bronze Alloys Outlast those "other" Bronzes!**

MoldStar® Bronze materials for wear application provide economical and performance advantages over laminated products for wear plate, bushing & sleeves applications.

### STANDARD MOLD COMPONENTS

#### **PERFORMANCE CORE PINS®**

Performance Alloys® offers a complete line of off the shelf Performance Core Pins® in the best Beryllium-Free materials.

#### **PERFORMANCE SPRUE BUSHINGS®**

Performance Alloys® has a Patented design on Performance Sprue Bushings® which offers you faster sprue cure rates to reduce mold cycles. Available in standard and custom sizes to match your needs, and a brand new carbide lined sprue for abrasive resins.

### PLUS: Machining Services Offered

Performance Alloys® offers finished machine components to your specifications. Components can be made from conductivity alloys or toolsteels. We can also supply complete with all popular hardness and release coatings. Short lead times and close tolerances are our Commitment to Excellence.

### Shipping

Direct shipments can be arranged worldwide to almost anywhere.

***CYCLE REDUCTIONS AND QUALITY IMPROVEMENTS ARE NOT JUST BUZZ WORDS FOR US, THEY ARE FACTS.***

#### **CALL with YOUR SPECIFIC APPLICATION**

#### **MoldStar® 90 @ 31 Rockwell "C"**

A Truly NEW Copper Alloy with the BEST Balance of HARDNESS & CONDUCTIVITY

#### **MoldStar® 150 @ 18-22 Rockwell "C"**

Available in a broad range of sizes and forms

#### **MoldStar® 18, 21 & 22 Bronzes**

Full Range of Sizes, Standard & Custom

#### **PERFORMANCE CORE PINS®**

The NEW STANDARD IN OFF THE SHELF HIGH CONDUCTIVITY COPPER ALLOY MOLD COMPONENTS

#### **PERFORMANCE SPRUE BUSHINGS®**

SPEED UP MOLDS WHERE THE SPRUE IS LIMITING OR CONTROLLING THE CYCLE

#### **PERFORMANCE SPRUE BUSHINGS®**

**CARBIDE LINED (for abrasive resins)**  
PLUS SPEEDS UP THE CYCLE BY DESIGN

#### **EJECTOR PINS**

THRU HARD FOR DEMANDING MOLDS

#### **PLUS COMPONENTS OF ALL TYPES**

**MADE IN OUR FACILITY TO MEET YOUR DEMANDING APPLICATIONS**

## MoldStar® Material Recommendations

MoldStar® 150 (PAS 940)	Cu 96.4 Ni 2.5 Si 0.7 Cr 0.4	Very high thermal conductivity, resistance to corrosion and wear, moderate hardness	Mold cores, cavities, sprue bushings, hot runner systems, core pins, ejector pins, sleeves, blow pins
MoldStar® 90	Cu 89.0 (est) Ni 7.5 (est) Other 3.5 (max.)	Excellent Balance of thermal conductivity, Hardness & corrosion resistance and wear	Mold inserts, thermal pins, mold cores, cavities, lifters, etc,
MoldStar® 18 (PAS 18)	Cu 85.5 Al 10.5 Fe 3.5 Other 0.5 (max.)	Good bearing qualities, resistance to wear, abrasion, fatigue, deformation and corrosion	Slides, gibs, wear plates, mold locking devices, sleeve bearings, guide pin bushings, guide rails
MoldStar® 21 (PAS 21)	Cu 80.2 Al 12.8 Fe 4.5 Other 2.5 (max.)	Harder alloy with good bearing qualities, resistance to wear, abrasion, fatigue, deformation and corrosion	Lifter blades, slides, gibs, wear plates, ejector sleeves and bushings, guide pin and leader pin bushings
MoldStar® 22 (PAS 22)	Cu 78.7 Al 13.8 Fe 5.0 Other 2.5 (max.)	Harder alloy with good bearing qualities, resistance to wear, abrasion, fatigue, deformation and corrosion	Ejector sleeves, lifter blades, thin wall applications, ejector and core pins, guide pin and leader pin bushings, unscrewing mold components

### ***BRINGING INDUSTRY THE NEWEST AND VERY BEST PRODUCTS***

All the **MoldStar®** Alloys have been carefully developed & application tested to provide you with the performance characteristics Performance Alloys is best known for. **GUARANTEED!**

The **PERFORMANCE ALLOYS®** & **MoldStar®** names mean **BEST** Quality, Availability, Value & Support.

Toll Free: 1-800-272-3031  
 Phone: 1-262-255-6662  
 Fax: 1-262-255-3655  
 E Mail: nobecuco@aol.com  
 Web Site: [www.performancealloys.net](http://www.performancealloys.net)

**Popular Mold Building Materials  
Specifications and Comparisons**

	Thermal Conductivity at 68 <sup>0</sup> F Btu/ft/hr/ft <sup>2</sup> / <sup>0</sup> F	Thermal Diffusivity at 68 <sup>0</sup> F ft <sup>2</sup> /hr	Brinell Hardness 3,000 kg	Density lbs/cu.in.
MoldStar® 150 (PAS 940)	150	2.32	210 (94R <sub>b</sub> )	.315
MoldStar® 90	90	1.76	311 (31R <sub>c</sub> )	.310
MoldStar® 18 (PAS 18)	36	.97	192 (92R <sub>b</sub> )	.269
MoldStar® 21 (PAS 21)	25	.62	286 (29R <sub>c</sub> )	.260
MoldStar® 22 (PAS 22)	25	.62	331 (35R <sub>c</sub> )	.255
Aluminum QC7®	80	2.44	167 (500kg)	.101
PROtherm® (Beryllium-0.5%)	145	2.32	157-210 (500kg)	.319
moldMAX® (Beryllium 2.0%)	60	1.16	300-380	.297
Tool Steel P20	20	0.39	265-345	.284
Tool Steel H13	17	0.31	350-530	.284
Stainless Steel	7	0.16	150-190	.284

	Tensile Strength ksi	Yield Strength ksi	Compressive Strength ksi	Coefficient of Expansion in/in/ <sup>0</sup> F x10 <sup>6</sup>	Elongation % in 2"
MoldStar® 150	100	75	80	9.7	13
MoldStar® 90	150	140	140	9.5	5
MoldStar® 18	105	52	38	9.0	14
MoldStar® 21	110	60	61	9.0	1
MoldStar® 22	105	62	74	9.0	0.5
Aluminum QC7®	78	74	65	12.8	7
PROtherm®Beryllium 0.5%	110	90	90	9.8	10
moldMAX®Beryllium2.0%	175	150	150	9.7	7
Tool Steel P20	150	125	125	7.1	20
Tool Steel H13	250	200	225	6.1	15
Stainless Steel	82	36	80	6.5	69



## MoldStar® 90

**Our NEWEST beryllium-free copper alloy for the blow molding and injection molding industries as well as other Industrial Applications**

After working closely with our customers in their demanding applications it became obvious we needed to develop application specific alloys.

Performance Alloys has done exactly that!

Just like our service is focused to address the shortcomings of our competitors, MoldStar® alloys have been carefully developed to specifically address the shortcomings of competitive products.

In side by side applications, MoldStar® 90 has shown measurable advantages over PROtherm®, moldMAX® & even MoldMATE®.

MoldStar®90 available in ROUND Bar & PLATE Sizes

- ROUND BAR from 3/8 " up to 4" Diameter
- PLATE SIZES from 1/2" up to 5" Thickness

Call us to find out the sizes available for your next application. Experience first hand the Performance Alloys and MoldStar® difference.

IF NEEDED SEE WELDING SECTION FOR INFORMATION

1-800-272-3031 or 1-262-255-6662

The accompanying table compares thermal conductivity of MoldStar® 90 with other commonly used mold materials.

Mold Material	Thermal Conductivity (Btu/hr/ft/°F)
MoldStar® 90	90
moldMAX® 2% Beryllium	60
Aluminum	90
Tool Steel (S7)	21
Tool Steel (P20)	20
Tool Steel (H13)	17



Performance Core Pins using MoldStar® Alloys



Materials for Cores for virtually any High Volume Mold Application

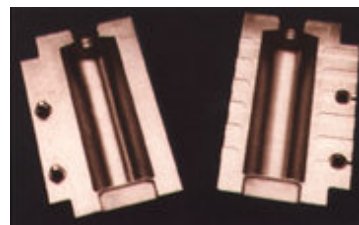

Excellent for Blow Mold Cavities

---



## MoldStar® 150 (PAS 940)

**the high-performance, beryllium-free copper alloy  
for the blow molding and injection molding industries**

Applications have proven MoldStar®150 as THE dependable material of choice for blow molding and injection molding applications.

In many mold applications, the placement of cooling passages is dictated by mold shape, size and complexity. The excellent thermal conductivity of MoldStar® alloys help compensate for uneven wall thickness or part configuration.

In a tested application, core temperatures during mold cycles ranged from 120-140°F with tool steel components. The addition of MoldStar® inserts reduced temperatures to 80-90°F. In addition to lower temperatures, there was less of a temperature variation, resulting in greater stability from cavity to cavity.

The accompanying table compares thermal conductivity of MoldStar® 150 with other commonly used mold materials.

Mold Material	Thermal Conductivity (Btu/hr/ft/°F)
MoldStar®150	150
PROtherm® .5% Beryllium	145
Aluminum	90
Tool Steel (S7)	21
Tool Steel (P20)	20
Tool Steel (H13)	17

In addition to its superior thermal conductivity, MoldStar®150 offers the following advantages:

- Accepts and maintains high surface finishes
- Accepts etching and texturing.
- Offers welding compatibility with other copper alloys, tool steels and stainless steels to provide composite materials for increased surface hardness in specific areas. SEE WELDING SECTION FOR INFORMATION
- Requires no additional heat treatment.
- Retains the inherent corrosion resistance of copper. Can be readily machined using conventional practices as well as the electrical discharge method (EDM).

MoldStar®150 can be produced in various forms to customer requirements. In addition, the material is stocked in round rod, rectangular bar and plate.



MoldStar® core pins with standard tool steel sleeve



Mold cores for plastic overcaps of pressurized containers

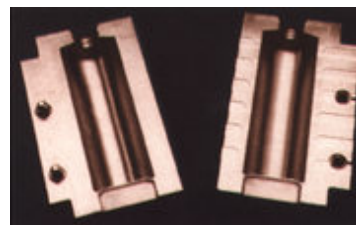

Blow mold for a PVC container

# BERYLLIUM-FREE COPPER ALLOYS

**MoldStar® 150 (PAS 940) FOR MOLD CORES / CAVITIES  
AND OTHER APPLICATIONS**

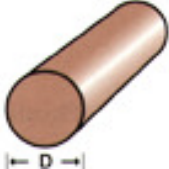
<b>ROUND ROD</b>		 <p><b>Round bar or plate, no order is too small. We will cut to size any piece of material.</b></p>			
<b>DIAMETER (inches)</b>	<b>WEIGHT (pounds per foot)</b>	<b>NOMINAL DIAMETER</b>	<b>DIAMETER (inches)</b>	<b>WEIGHT (pounds per foot)</b>	<b>NOMINAL DIAMETER</b>
1/4	.21	.263	1-3/4	9.12	1.750
3/8	.44	.385	2	11.89	2.00
15/32	.66	.468	2-1/4	15.08	2.250
1/2	.84	.532	2-1/2	18.61	2.500
19/32	1.05	.594	2-3/4	22.51	2.750
5/8	1.28	.658	3	26.79	3.00
3/4	1.82	.783	3-1/8	29.07	3.125
7/8	2.27	.875	3-1/4	31.48	3.250
1	2.97	1.00	3-1/2	36.49	3.500
1-1/8	3.76	1.125	3-5/8	39.13	3.625
1-1/4	4.66	1.250	4	47.67	4.00
1-3/8	5.62	1.375	4-1/2	60.48	4.500
1-1/2	6.69	1.500	5-1/8	78.23	5.125

<b>PLATE</b>		
<b>THICKNESS (inches)</b>	<b>THICKNESS TOLERANCE</b>	<b>NOMINAL THICKNESS</b>
1/2	+.038	.536
3/4	+.048	.786
1	+.060	1.036
1-1/2	+.060	1.550
2	+.060	2.050
2-1/2	+.060	2.550
3	+.060	3.050
3-1/2	+.060	3.530
4	+.060	4.030

Need a size of Round Stock, Rectangle or Rings other than what is published?

**NO PROBLEM! We can custom forge pieces up to 3500 POUNDS with lead times to meet your needs!**

Need more than just a piece of material?

**We are your reliable source for milling, turning, conventional and wire EDM work, centerless grinding and blanchard grinding.**

## How We Stack Up To The Competition!!

Toll Free: 1-800-272-3031 Fax: 1-262-255-3655 e-mail: nobecu@aol.com

In 1995 a Mold Task Force group was organized by the Copper Development Association to promote the use of copper alloys in molds for plastics.

Part of the activity of the group and the CDA was to fund research projects at Western Michigan University to compare popular mold steels with beryllium copper and our beryllium-free copper alloys.

The mold components made from the various materials were carefully engineered and constructed to eliminate any potential for variation that might be caused by the tooling itself.

The initial testing focused on cycle time reduction, quality changes and component performance. The tests were to observe those conditions by varying the mold core material combined with reductions to mold cool time only. The tests were strictly controlled to insure that there were no changes to water temperature, water flow rates, injection rate and the mold open time.

In April 1996, results were published by the Western Michigan University that showed our Beryllium-Free PAS 940 alloy performed consistently better than both moldMAX® and PROtherm® beryllium copper alloys.

In fact, our alloy performed consistently 7% faster than PROtherm®. Along with faster cycles the part proved better by quality observations. The differences in cycle times between PROtherm® and moldMAX® were less than 5%.

These test results are extremely important to people using or considering using moldMAX® or PROtherm®.

Why?

Because the manufacturers of PROtherm® and moldMAX® claim in advertising and sales presentations, that their products are substantially higher in mechanical and thermal properties than our 940 products. It is important to realize that the result of these tests and other independent comparisons **DO NOT** support the published data.

PROtherm® and moldMAX® are registered trademarks of Brush Wellman Engineered Materials Inc.

**The tests showed consistently and conclusively that 940 transferred heat better than either PROtherm® or moldMAX®. The tests also showed that even with the higher hardness offered by moldMAX®, there was no measurable benefit due to the hardness of that product in the experiments.**

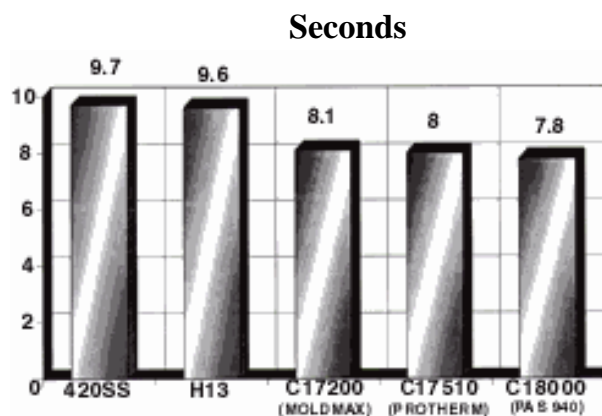

*Results As Published By Western Michigan University For Antec 96*

# MoldStar®18

## Continuous cast aluminum bronze rod/bar/tube

### Description

A continuous cast aluminum-iron-copper alloy (UNS-95400) meeting the minimum requirements of ASTM Standards. The excellent resistance of this alloy to wear and abrasion is available in continuous tube, round rod, and rectangular bar.

These characteristics make MoldStar®18 ideal for bushings, tie bar nuts, bearings, gears, worm gears, and similar applications.

### Chemistry

<b>Copper</b>	<b>85.5%</b>
<b>Aluminum</b>	<b>10.5%</b>
<b>Iron</b>	<b>3.5%</b>

### Mechanical Properties\*

Proportional Limit (ksi)	18.5
Compressive Strength-Ultimate (ksi)	.136
Fatigue Strength (ksi @ 10 <sup>8</sup> cycles)	36
Impact -Charpy Keyhole (ft.-lbs.)	15
Izod (ft.-lbs.)	22
Modulus of elasticity (ksi)	16,000
Poissan's Ratio	.316

\*based on 1" dia. test bars

Toll Free: 1-800-272-3031 Fax: 1-262-255-3655

### Physical Properties

Density (lbs./in. <sup>3</sup> )	.269
Specific Gravity	7.45
Specific Heat (Btu/lb./°F)	.10
Coefficient of Thermal Expansion (in./in./°F)	9.0 x 10 <sup>-6</sup>
Electrical Conductivity (% IACS)	13
Electrical Resistivity (Microhms-Meter @ 68°F)	133
Thermal Conductivity (Btu/sq.ft./ft./hr./°F @ 68°F)	34
Magnetic Permeability	1.3

Specifications	
ASTM	B148 C95400** B505 C95400
ASME	SB148 C95400**
Federal	QQ-C 390 C954 Type III as cast
Military	B-16033 Amend 2, Class 3
SAE	J462 C95400B
CDA	C95400

\*Waive method of manufacture

## MoldStar®18 Continuous cast aluminum bronze rod/bar/tube

### Mechanical Properties

Moldstar®18	Tensile Strength ksi Min.	Yield Strength ksi Min.	Elongation % in 2" Min.
	85	32	12

*Typical Applications include:*

- Wear Plates
- Gibs and Ways
- Gear Racks
- Wear Strips
- Support Rails
- Lifter Blades
- Guides
- Liners
- Keys
- Leader Pin Bushings
- Ejector Sleeves
- Hold-Down Bars
- Straightening Dies
- Lead Nuts for Unscrewing Molds

**MoldStar® 18**  
**Round Extruded Aluminum Bronze Rod**  
 12 Foot Mill Lengths



**Rectangular MoldStar® 18**  
**Aluminum Bronze Bar**  
 UNS-C95400



**MoldStar® 18**  
**Hollow Aluminum  
 Bronze Bar**



**MoldStar®18 (95400)**

**MoldStar® 18**  
**Round Extruded Aluminum Bronze Rod**  
 12 Foot Mill Lengths



NOMINAL O.D.	APPROX. WT.		NOMINAL O.D.	APPROX. WT.	NOMINAL O.D.	APPROX. WT.
1/2	10		3	294	5	803
3/4	22					
1	35					
1-1/4	54		3-104	344	5-1/4	881
1-4/2	75		3-1/2	401	5-1/2	970
1-5/8	87		3-3/4	456	5-3/4	1067
1-3/4	101					
2	133		4	514	6	1147
			4-1/4	586	6-1/4	1235
			4-1/2	658	6-1/2	1330
			4-3/4	733	7	1538
					8	2003
2-1/4	165				9	2569
2-1/2	207					
2-3/4	249					

Toll Free: 1-800-272-3031 Fax: 1-262-255-3655 e-mail: nobecu@aol.com

**MoldStar®18 (95400)**

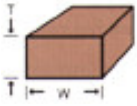

**Rectangular MoldStar® 18  
Aluminum Bronze Bar  
UNS-C95400**

THICKNESS IN INCHES	WIDTH IN INCHES	THICKNESS IN INCHES	WIDTH IN INCHES	THICKNESS IN INCHES	WIDTH IN INCHES
1/4X	1 1-1/4 1-1/2 2 2-1/2 3 4 6 12	5/8X	3 4 5 6	1-1/4X	3 3-1/2 4 5 6 12
3/8x	1 1-1/2 2 2-1/2 3 3-1/2 4 5 6 12	3/4x	3/4 1 1-1/2 1-3/4 2 2-1/2 3 3-1/2 4 5 6 12	1-1/2x	1-1/2 1-3/4 2 2-1/2 3 3-1/2 4 5 6 12
1/2x	1 1-1/4 1-1/2 1-3/4 2 2-1/2 3 3-1/2 4 5 6 8 12	1x	1 1-1/4 1-1/2 1-3/4 2 2-1/2 3 3-1/2 4 5 6 12	1-3/4x	2 2-1/2 3 4 5 6
5/8x	1 1-1/2 2 2-1/2	1-1/4x	1-1/4 1-1/2 1-3/4 2 2-1/2	2x	2 2-1/2 3 3-1/2 4 5 6
				2-1/2x	2-1/2 3 4 5
				3x	3



**MoldStar®18 (95400)**

Chemical Composition (%)	
Copper	85.5
Aluminum	10.5
Iron	3.5
Other	0.5 (max.)

The excellent resistance of Moldstar®18 alloy to wear and abrasion is available in continuous-cast round and hollow bars. These characteristics make MoldStar® 18 ideal for bushings, tie-bar nuts, bearings, gears, worm wheels, and similar applications.

Weights in pounds Measures in inches

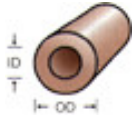
<p><b>MoldStar® 18</b>  <b>Hollow Aluminum</b>  <b>Bronze Bar</b></p>						
NOMINAL		APPROX.	NOMINAL		APPROX.	
I.D.	O.D.	WT.	I.D.	O.D.	WT.	
3/4x	1-1/4	39	2-1/2x	3	110	
	1-1/2	61		3-1/4	162	
	1-3/4	87		3-1/2	224	
	2	117		3-3/4	283	
				4	343	
				4-1/2	479	
				5	631	
				6	984	
1x	1-1/2	49		2-3/4x	3-1/4	121
	1-3/4	75			3-1/2	182
	2	104			3-3/4	240
	2-1/4	138			4	307
	2-1/2	181	4-1/4		375	
3	270	4-1/2	444			
1-1/4x	1-3/4	59	3x	3-1/2	143	
	2	88		3-3/4	199	
	2-1/8	105		4	260	
	2-1/4	126		4-1/4	327	
	2-1/2	166		4-1/2	397	
	2-3/4	208		5	556	
	3	253		5-1/2	705	
	3-1/2	363		6	897	
				7	1286	

Toll Free: 1-800-272-3031 Fax: 1-262-255-3655 e-mail: nobecu@aol.com

## MoldStar®18 Hollow Aluminum Bronze Bar (continued)

I.D.	O.D.	APPROX. WT.	I.D.	O.D.	APPROX. WT.
1-1/2x	1-7/8	51	3-1/4x	3-3/16	150
	2	67		4	211
	2-1/4	101		4-1/4	231
	2-3/7	124		4-1/2	349
	2-1/2	145		5	495
	2-3/4	187	3-1/2x	4	163
	3	233		4-1/4	281
	3-1/4	289		4-1/2	296
	3-1/2	341		5	445
	3-3/4	397		5-1/2	617
4	462	6	795		
4-1/2	598				
1-3/4x	2-1/8	60	3-3/4x	4-3/4	317
	2-1/4	78	4x	4-1/2	184
	2-1/2	119		4-3/4	258
	2-3/4	163		5	332
	3	209		5-1/2	502
	3-1/4	258		6	680
	3-1/2	319		7	1080
	3-3/4	377		8	1543
	4	438			
2x	2-3/8	73	4-1/4x	5	273
	2-1/2	92	4-1/2x	5	209
	2-3/4	135		5-1/4	287
	2-7/8	157		5-1/2	376
	3	182		6	551
	3-1/4	230		6 1/2	761
	3-1/2	292	5x	5-1/2	224
	3-3/4	349		5-3/4	324
	4	412		6	409
	4-1/2	546		7	812
	5	696		8	1277
6	1036				
2-1/4x	2-5/8	80	5-1/2x	6-1/2	448
	2-3/4	103	6x	7	485
	3	150		8	949
	3-1/4	198	6-1/2x	7-1/2	525
	3-1/2	262	6-3/4x	7-3/4	543
	3-3/4	313	7x	8	561
	4	380			

Toll Free: 1-800-272-3031    Fax: 1-262-255-3655    e-mail: nobecu@aol.com

## MoldStar® 21

### extruded and continuous cast aluminum bronze rod and bar

#### Description

A wrought (UNS-C62500) or cast (UNS-C95900) aluminum-iron-copper alloy recommended for heavier-duty applications involving compressive wear and high abrasion, especially where no impact is present.

Uses include: die rings, forming rolls, inserts, wiping blocks, cam followers, pilot bushings, dies and drill jig bushings. Also, offers proven performance in plastic mold applications - ejector sleeves and bushings, guide pin and leader pin bushings, wear plates, gibs.

This alloy will maintain mechanical properties at temperatures up to 600 °F and has a machinability rating of 20%. The alloy provides corrosion resistance to non-oxidizing mineral acids. Can be welded with both gas-shielded and shielded metal-arc processes. Brazing, soldering and oxyfuel gas welding are not recommended.

Cold working is not recommended. Hot formability is good with a forgeability rating of 75%. The alloy can be hot worked at temperatures from 1375° to 1550°F and annealed between 1100° and 1200°F.

The consistent superiority of our alloys over commercial bronze is due, in large part, to the unique distribution of alloy microstructure.

#### Chemistry

<b>Copper</b>	<b>83%</b>
<b>Aluminum</b>	<b>13%</b>
<b>Iron</b>	<b>4%</b>

#### Specifications

CDA C62500, C95900

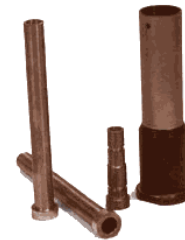

#### Mechanical Properties (based on 1" test bars)

Tensile Strength (ksi)	110+
Yield Strength (ksi)	60+
Elongation, % in 2"	.1+
Hardness- Rockwell C	29
Ultimate in Compression (ksi)	175
Proportional Limit (ksi)	34+
Impact - Charpy Keyhole (ft-lbs)	2
Izod (ft-lbs)	2
Modulus of Elasticity (tension), (ksi)	15,000
Poisson's Ratio	.312
*Properties are shown for comparative information only	

#### Physical Properties\*

Density (lbs/in <sup>3</sup> )	.260
Specific Gravity	7.21
Specific Heat (Btu/lb °F)	.09
Coefficient of Thermal Expansion (in/in/°F)	9.0 x 10 <sup>-6</sup>
Electrical Conductivity (% IACS)	10
Electrical Resistivity (Microhms-Meter @ 68°F)	172
Thermal Conductivity (Btu/sq. ft./ft./hr./°F @ 68°F)	22.5
Magnetic Permeability	1

**MoldStar® 21 (95900)  
FOR THE MOLD INDUSTRY**

Typical Applications include:

- Wear Plates
- Gibs and Ways
- Gear Racks
- Wear Strips
- Support Rails
- Lifter Blades
- Guides
- Liners
- Keys
- Leader Pin Bushings
- Ejector Sleeves
- Hold-Down Bars
- Straightening Dies
- Lead Nuts for Unscrewing Molds

<b>MoldStar® 21 Round Extruded Aluminum Bronze Rod 12 Foot Mill Lengths</b>			
<b>Nominal Size</b>	<b>Cast Size</b>	<b>Lbs/In</b>	
1	1.063	0.24	
1-1/2	1.563	0.51	
2	2.063	0.89	
2-1/2	2.563	1.37	
3	3.063	1.95	
3-1/2	3.594	2.69	
4	4.094	3.49	
4-1/2	4.625	4.45	
5	5.125	5.47	
6	6.188	7.97	
7	7.188	10.75	
8	8.188	13.95	

Continued

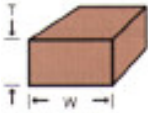

**Rectangular MoldStar® 21  
Aluminum Bronze Bar  
12 Foot Mill Lengths**

Nominal Size		Cast Size	Lbs/In	Nominal Size		Cast Size	Lbs/In
1/4x	1	0.313 x 1.063	0.09	1x	1-1/4	1.063 x 1.313	0.36
	1-1/4	0.313 x 1.313	0.11		1-1/2	1.063 x 1.563	0.43
	1-1/2	0.313 x 1.563	0.13		1-3/4	1.063 x 1.813	0.50
	2	0.313 x 2.063	0.17		2	1.063 x 2.063	0.57
	2-1/2	0.313 x 2.563	0.21		2-1/2	1.063 x 2.563	0.71
	3	0.313 x 3.063	0.25		3	1.063 x 3.063	0.85
3/8x	4	0.313 x 4.063	0.33		3-1/2	1.063 x 3.563	0.98
	1	0.438 x 1.063	0.12		4	1.063 x 4.063	1.12
	1-1/2	0.438 x 1.563	0.18		4-1/2	1.063 x 4.563	1.33
	2	0.438 x 2.063	0.23		5	1.063 x 5.063	1.40
	2-1/2	0.438 x 2.563	0.29		5-1/2	1.063 x 5.563	1.60
	3	0.438 x 3.063	0.35		6	1.063 x 6.063	1.68
6	4	0.438 x 4.063	0.46	1-1/4x	1-1/4	1.313 x 1.313	0.41
	5	0.438 x 5.063	0.60		1-1/2	1.313 x 1.563	0.53
0.438 x 6.063	0.69	1-3/4	1.313 x 1.813		0.62		
1/2x	1/2	0.563 x 0.563	0.08		2	1.313 x 2.063	0.70
	1	0.563 x 1.063	0.16		2-1/2	1.313 x 2.563	0.87
	1-1/2	0.563 x 1.563	0.23		3	1.313 x 3.063	1.06
	1-3/4	0.563 x 1.813	0.27	1-1/2x	1-1/2	1.563 x 1.563	0.64
	2	0.563 x 2.063	0.30		2	1.563 x 2.063	0.84
	2-1/2	0.563 x 2.563	0.38		2-1/2	1.563 x 2.563	1.04
	3	0.563 x 3.063	0.45		3	1.563 x 3.063	1.24
	3-1/2	0.563 x 3.563	0.54		3-1/2	1.563 x 3.563	1.48
4	0.563 x 4.063	0.59	4		1.563 x 4.063	1.65	
5	0.563 x 5.063	0.77	5		1.563 x 5.063	2.10	
6	0.563 x 6.063	0.89					

## Rectangular MoldStar® 21 Aluminum Bronze Bar (continued)

5/8x	1	0.688 x 1.063	0.19	1-3/4x	1-3/4	1.813 x 1.813	0.88
	1-1/2	0.688 x 1.563	0.28		2	1.813 x 2.063	0.98
	0.688 x 2.063	0.37	2-1/2		1.813 x 2.563	1.22	
	2-1/2	0.688 x 2.563	0.46		3	1.813 x 3.063	1.46
	3	0.688 x 3.063	0.55		3-1/2	1.813 x 3.563	1.72
	3-1/2	0.688 x 3.563	0.66		4	1.813 x 4.063	1.96
	4	0.688 x 4.063	0.73		5	1.813 x 5.063	2.44
3/4x	6	0.688 x 6.063	1.08	2x	2	2.063 x 2.063	1.11
	3/4	0.813 x 0.813	0.17		2-1/2	2.063 x 2.563	1.38
	1	0.813 x 1.063	0.22		3	2.063 x 3.063	1.64
	1-1/2	0.813 x 1.563	0.33		4	2.063 x 4.063	2.18
	1-3/4	0.813 x 1.813	0.38		5	2.063 x 5.063	2.72
	2	0.813 x 2.063	0.44		6	2.063 x 6.063	3.25
	2-1/2	0.813 x 2.563	0.54	2-1/2x	2-1/2	2.563 x 2.563	1.71
	3	0.813 x 3.063	0.65		3	2.563 x 3.063	2.04
	3-1/2	0.813 x 3.563	0.78		3-1/2	2.563 x 3.563	1.95
	4	0.813 x 4.063	0.86		4	2.563 x 4.063	2.71
	4-1/2	0.813 x 4.563	1.02		5	2.563 x 5.063	3.45
	5	0.813 x 5.063	1.10				
	5-1/2	0.813 x 5.563	1.25				
6	0.813 x 6.063	1.28					
1x	1	1.063 x 1.063	0.29	3x	3	3.063 x 3.063	2.44

## MoldStar® 22 ALUMINUM BRONZE

MoldStar® 22 is a harder alloy with good bearing qualities, resistance to wear, abrasion, fatigue, deformation and corrosion. This material is ideal for ejector sleeves, lifter blades, thin wall applications, guide pin and leader pin bushings, and unscrewing mold components.

<b>SOLID ROUNDS</b>		
<b>Diameter (inches)</b>	<b>Weight (lbs./ft.)</b>	<b>Nominal Diameter</b>
1	2.75	1.06
1-1/4	3.82	1.25
1-1/2	6.35	1.61
1-3/4	8.20	1.83
2	11.86	2.20
2-1/2	16.56	2.60
3	25.09	3.20

Call us to verify Stock Sizes  
1-800-272-3031



### MoldStar® 22 Chemical Composition

<b>Copper</b>	<b>78.7%</b>
<b>Aluminum</b>	<b>13.8%</b>
<b>Iron</b>	<b>5.0%</b>
<b>Other</b>	<b>2.5 %(max.)</b>



<b>Mechanical Properties</b>			
Thermal Conductivity at 68°F Btu/ft/hr/ft <sup>2</sup> /°F	25	Yield Strength ksi	62
Thermal Diffusivity at 68°F ft <sup>2</sup> /hr	.062	Compressive Strength ksi	74
Brinell hardness 3,000kg	331 (35R <sub>c</sub> )	Coefficient of Expansion in/in/°F	9.0
Tensile Strength ksi	105	Elongation % in 2"	.05



## PERFORMANCE CORE PINS®

PERFORMANCE CORE PINS® is one of the fastest growing products in the mold making industry today.

That is because PERFORMANCE CORE PINS® perform beyond our product claims in most applications. In addition to the unmatched performance, we offer superior quality with product availability in more standard sizes than any conductivity pin on the market.

When it comes to cost, PERFORMANCE CORE PINS® provide one of the fastest returns on investment possible for any mold component used by the industry. Product cost is insignificant when you see the results of quality and productivity improvement in your finished products.

When you use a PERFORMANCE CORE PIN® in place of a conventional steel core pin or beryllium copper pin, without any other change to the mold, you will see improvement in the cooling of the plastic in the area affected by the pin.

This means faster cycles are possible, with higher quality parts, less scrap, less lost production. The overall results is more and higher profits.

Many mold makers and molders define "adequate cooling" as good water flow rates in close proximity to the molding surface. Many mold makers and molders are of the opinion that if the core pin or mold design will not facilitate water directly in the pin, that there is no reasonable cooling opportunity. Many molders don't believe they have a problem with heat transfer and cooling with their steel components. These mold makers and molders obviously haven't tried PERFORMANCE CORE PINS®.

Our product is made from a Beryllium-Free Copper Alloy that allow PERFORMANCE CORE PINS® to transfer heat far better than standard steel core pins (6 -10 times), even better than MOLDMAX® brand of beryllium-copper core pins (2 times)

### QUALITY/MOLD CYCLE LIMITED BY CORE PINS

If you design, build or run molds that have any other core pin than a PERFORMANCE CORE PIN®, the piece part quality is not as good as what it could be and the mold is not performing to capacity. Try a PERFORMANCE CORE PIN® in your application, see the *PERFORMANCE* difference.

### GLASS-FILLED RESIN APPLICATIONS

PERFORMANCE CORE PINS® can be titanium nitride (TiN) coated or chrome plated to provide wear resistance for abrasive filled resins. The TiN or chrome will provide the same additional wear life, as if applied to steel. And in certain abrasive resin applications without TiN, molders say that the pin life cycle and replacement costs are substantially offset by the benefits of added cooling and the increase in mold productivity.

### PIN FITS & SHUT OFFS

Many molders have found that by using PERFORMANCE CORE PINS®, they are able to run flash-free parts, with more pin fit clearance and/or shut-off clearance, than would be allowable with conventional steel core pins.

## **PERFORMANCE CORE PINS® (Continued)**

### **SLEEVE APPLICATIONS**

Titanium Nitride (TiN) coating is recommended on a PERFORMANCE CORE PIN® in the sleeve contact area. Although uncoated PERFORMANCE CORE PINS® used in sleeve applications, have worked well because of the reduced coefficient of friction between the copper alloy pin and the steel sleeve. Sleeve and pin wear is always more prevalent in molds that are designed without "guided" ejector systems regardless of the core pin material. In unguided systems, pin life can be compromised without the Titanium Nitride (TiN) coating.

## PERFORMANCE CORE PINS®

### 10000 SERIES\*

- Six times better conductivity than steel
- Two times better conductivity than beryllium copper core pins
- Made from MoldStar® 150 material
- Hardness 95-98 Rockwell "B"  
(20-25 Rockwell "C")



### PERFORMANCE PIN ADVANTAGES

- Higher tensile strength than P-20 toolsteel
- BERYLLIUM FREE
- Retains the inherent corrosion resistance of copper
- Provides control over cycle times
- Reduces post-mold shrinkage problems
- Requires no additional heat treatment
- Suitable for service in ejector sleeves while providing dissimilar metal and compatible coefficient of friction to reduce metal to metal pick up and wear
- Tens of thousands of successful applications

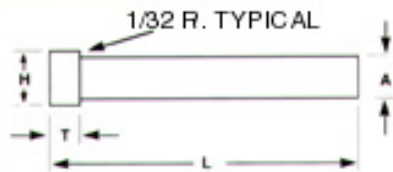

TOLERANCES			
Pin Diameter (A)	+0.001 -0.000	Head Thickness (T)	+0.000 -0.002
Head Diameter (H)	-0.000 -0.010	Length (L)	+0.375 -0.00

SPECIFICATIONS			
CP10000 Series	"A" Pin Dia.	"H" Head Dia.	"T" Head Thick.
10093	3/32	1/4	1/8
10109	7/64	1/4	1/8
10125	1/8	1/4	1/8
10140	9/64	1/4	1/8
10156	5/32	9/32	5/32
10171	11/64	11/32	3/16
10187	3/16	3/8	3/16
10203	13/64	3/8	3/16
10218	7/32	13/32	3/16
10250	1/4	7/16	3/16
10281	9/32	7/16	1/4
10312	5/16	1/2	1/4
10343	11/32	9/16	1/4
10375	3/8	5/8	1/4
10406	13/32	11/16	1/4
10437	7/16	11/16	1/4
10468	15/32	3/4	1/4
10500	1/2	3/4	1/4
10562	9/16	13/16	1/4
10625	5/8	7/8	1/4
10750	3/4	1"	1/4

**WHEN ORDERING SPECIFY QUANTITY, CATALOG NUMBER, and "L" DIMENSION**

Available in lengths of 3", 6", 14", 20"-Specify (L)  
**See Price List for Standard Sizes/Prices**  
 Other Sizes available upon request.

\*Performance Core Pins® are produced under U.S. Patent, #5,020,770

# High Conductivity Core Pins

<b>PRICE LIST (*POR notes Price by Request for non stock)</b>				
<b>CP 10000 Series</b>	<b>3"</b>	<b>6"</b>	<b>14"</b>	<b>20"</b>
10093	13.95	15.55	22.20	POR
10109	POR	POR	POR	POR
10125	12.88	14.50	20.56	29.85
10140	POR	POR	POR	POR
10156	13.78	15.38	21.76	31.57
10171	13.12	15.38	21.76	POR
10187	13.28	15.38	21.09	30.62
10203	13.29	15.38	21.07	POR
10218	15.06	17.33	25.46	36.73
10250	14.68	17.33	25.46	35.96
10281	13.95	17.33	25.46	POR
10312	14.08	17.33	25.46	34.82
10343	17.04	22.26	31.99	POR
10375	17.33	22.26	32.39	46.83
10406	21.26	25.67	41.61	POR
10437	21.26	25.67	41.61	POR
10468	POR	POR	POR	POR
10500	20.88	25.29	41.08	POR
10562	24.15	30.33	51.18	POR
10625	23.42	29.61	50.17	POR
10750	25.71	33.77	59.06	POR



## PERFORMANCE SPRUE BUSHINGS®

PERFORMANCE SPRUE BUSHINGS® are recommended by a variety of resin manufacturers, molders, mold makers, designers and engineers as a product that works, is truly a straightforward, uncomplicated processing aide.

The PERFORMANCE SPRUE BUSHING® is available in a number of popular standard sizes, with non standards offered at reasonable prices with quick deliveries.

Many users are so pleased with the overall performance of this product that the PERFORMANCE SPRUE BUSHING® is now specified in all of the molds they build.

Try one, you will not be disappointed.

**Prices on standards are between \$243.00 - \$271.00 (Carbide-lined slightly higher.)  
We can also supply with a "wire start" hole only for customer finished internal detail**

### CYCLE TIMES LIMITED BY SPRUE

Mold cycles are often limited or controlled by the length of time needed for the solidification of the plastic sprue. The sprue must be cool enough not to break or tear as the mold is opened. Or, when molding small parts where the parts could be ejected, but the sprue is not solid enough to allow mold opening, there is added time just for sprue cooling. These cycle limiting conditions can be changed by using the Performance Sprue Bushing®, without any other changes to the mold.

### CORROSION & STICKING SPRUES

Many plastic resins, additives, colorants and combinations lead to corrosion and sticking problems with conventional steel sprue bushings. The inherent corrosion resistance and release properties of the copper alloy used in the Performance Sprue Bushing® offers a significant increase in performance and product life compared to conventional steel sprue bushings.

### SPRUES AS ROBOT GRAB POINTS

The sprue is often used as the grab point in robotic removal of parts, sprues and runners. This requires that the sprue be rigid enough to resist the pressure of the robot fingers as well as the extraction forces. With conventional steel sprues this measure is most often met by added cooling time to the mold cycle. The Performance Sprue Bushing® will again reduce the sprue cool time, without any other changes to the mold. Use of this product will yield more rigid sprues with reduced cool times set on the molding machine timer.

### PREVENTING MOLDING PROBLEMS CAUSED BY SPRUES

Molders that use Performance Sprue Bushings® in a variety of mold and resin applications say they are able to control many sprue related problems. They no longer "just struggle with sprue problems".

CALL US WITH YOUR APPLICATION TODAY TOLL FREE 1-800-272-3031

# PERFORMANCE Sprue Bushings®

## PERFORMANCE SPRUE BUSHING® ADVANTAGES

- Beryllium-Free Copper Alloy body for fast Heat Transfer
- Stainless Steel Nozzle Seat for wear resistance and to insulate nozzle heat
- Reduced cycle time due to faster sprue cooling rates
- Rigid sprues for improved targets for sprue pickers
- Eliminate "sticking sprues" due to inherent release properties of copper alloys
- Quality and productivity improvement due to consistency and repeatability of operation
- Highly corrosion resistant to resins such as PVC & Others
- Reduce scrap caused by product/hot sprue contact on conveyor or in drop boxes
- Recognized by Eastman as an advantage in processing their resin
- U.S. Patent Number 4,950,154

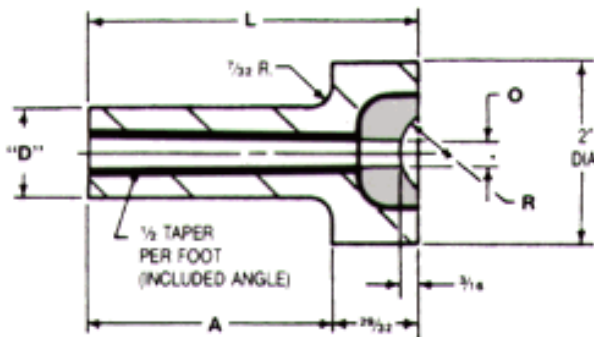

Made of MoldStar®150 material (Beryllium-free) with hardened 420 S.S. insert at nozzle seat area.

### SPECIFICATIONS

SPECIFICATIONS		
PB SERIES "D"=1,000 Diameter Shank	"A"	"L"
PB 6602	1 <sup>29/32</sup>	2 <sup>25/32</sup>
PB 6606	3 <sup>29/32</sup>	4 <sup>25/32</sup>
PB 6608	4 <sup>29/32</sup>	5 <sup>25/32</sup>
PC SERIES "D"=.750 Diameter Shank	"A"	"L"
PC 6602	1 <sup>29/32</sup>	2 <sup>25/32</sup>
PC 6606	3 <sup>29/32</sup>	4 <sup>25/32</sup>
PC 6608	4 <sup>29/32</sup>	5 <sup>25/32</sup>
Available in "O" - 5/32, 7/32, or 9/32		
Available in "R" 1/2 or 3/4		
OTHER SIZES AVAILABLE ON REQUEST PRICE AND DELIVERY ON REQUEST		

# PERFORMANCE Sprue Bushings®

with Tungsten Carbide channel to RESIST WEAR

## ADVANTAGES

- **CARBIDE-LINED** sprue channel, 77-80 R/C for Wear & Corrosion Resistance and Heat Transfer
- Beryllium-Free Copper Alloy body for super-fast Heat Transfer
- Hardened stainless steel nozzle seat as an insulating feature
- Reduces Mold Cycles due to Faster Sprue Cure Rates
- More rigid sprue for improved targets for robotic sprue pickers
- Stop sprue from sticking to robot fingers
- Reduce product loss/damage due to contact with hot sprue
- Reduce mold maintenance costs due to extended sprue life
- Runner/Part features in carbide insert must be wire or conventionally EDM'd
- Some applications may require hardened ring interface at end of bushing

**NEW**



For **ABRASIVE RESINS**

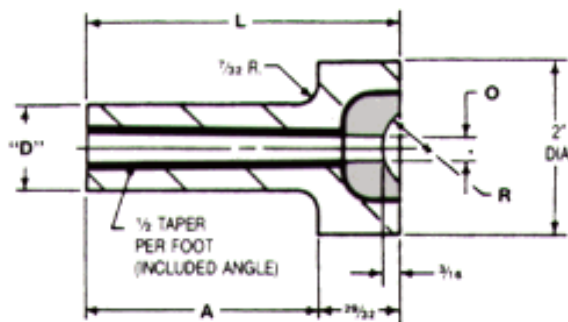

MoldStar®150 material (Beryllium free) body, with hardened 420 S.S. insert at nozzle seat area, Carbide-lined sprue channel

Manufactured under U.S. Patent 5,925,386

SPECIFICATIONS		
PB SERIES "D"=1,000 Diameter Shank	"A"	"L"
PB 6602 C	1 <sup>29/32</sup>	2 <sup>25/32</sup>
PB 6604 C	2 <sup>29/32</sup>	3 <sup>25/32</sup>
PB 6606 C	3 <sup>29/32</sup>	4 <sup>25/32</sup>
PB 6608 C	4 <sup>29/32</sup>	5 <sup>25/32</sup>
PC SERIES "D"=.750 Diameter Shank	"A"	"L"
PC 6602 C	1 <sup>29/32</sup>	2 <sup>25/32</sup>
PC 6604 C	2 <sup>29/32</sup>	3 <sup>25/32</sup>
PC 6606 C	3 <sup>29/32</sup>	4 <sup>25/32</sup>
PC 6608 C	4 <sup>29/32</sup>	5 <sup>25/32</sup>
Available in "O"- 5/32, 7/32, or 9/32 Available in "R" 1/2 or 3/4		
OTHER SIZES AVAILABLE ON REQUEST PRICE AND DELIVERY ON REQUEST		



You can also submit orders Online @www.performancealloys.net

# PERFORMANCE ALLOYS & SERVICES, INC.

N116 W18515 Morse Drive  
Germantown, WI 53022  
(262) 255-6662  
1-800-272-3031  
Fax (262) 255-3655

## REQUESTED SHIPPING:

NEXT DAY  2ND DAY  REGULAR  OTHER \_\_\_\_\_

QUOTE  ORDER  NEW ACCOUNT  EXISTING ACCOUNT

MSDS  YES  NO      CERTS.  YES  NO

<b>Contact</b>	<b>Your P.O. No.</b>
<b>Phone</b>	<b>Quote Date</b>
<b>Fax</b>	<b>Requested Ship Date</b>

<b>Sold To</b>	<b>Ship To</b>	<b>Referred By</b>
<b>Company</b>	<b>Company</b>	
<b>Address</b>	<b>Address</b>	

"P"=PLATE "B"=BAR "F"=FORGING

		<b>Qty</b>	<b>Grade</b>	<b>Size (we cut oversize to finish to)</b>	<b>Est. Wt.</b>	
1						
2						
3						
4						
5						
6						
7						

SPECIAL NOTES (include your drawings and/or specifications where applicable)

# Custom Orders

Dissatisfied with your current manufacturer? Or first considering outsourcing your **finished machine cores, sleeves, cavity bushings** or other **mold components**?

**Look to Performance Mold Products for unmatched quality, competitive prices, and on time deliveries.**

Performance Mold Products supplies many molders and moldmakers with finished machine components. We help molders and mold makers better utilize their shop and their technical people, to do what they do best. Simply by doing what we do best, making high quality mold components.

If you really need it in a hurry, though we can't get it done for you by yesterday, we may surprise you by saying the we can get it done for you today, tomorrow or in a week if you need it.

Our affiliation with a raw material supplier and our manufacturing capabilities for standard products puts Performance Mold Products in a unique position. We have immediate access to a variety of raw materials. And we even may have a machine or component in some stage of process where we can quickly respond to your needs.

**Consistently, year after year, we are rated at the highest levels for Quality, Service, Competitive Prices and on-Time Deliveries by our customers.**

New to outsourcing finished machine components? We will make that experience trouble free. I personally invite you to give us the opportunity to show you our level of quality and service. For Orders, Quotations you may:

- [Submit an Order, Pricing Request or Technical Support Online: www.performancealloys.net](http://www.performancealloys.net)
- Call us directly at 1-800-272-3031
- Or fax us at 262-255-3655

Cliff Moberg  
Performance Mold Products, Vice President  
Performance Alloys, President

# Hardened & Nitrided H-13 Ejector Pins

CAT NO.	PIN. DIA.	HEAD DIA.	HEAD THICK	CAT. NO.	PIN. DIA.	HEAD DIA.	HEAD THICK
PX3	1/32	1/4	1/8	PX22	21/64	9/16	1/4
PX4	3/64	1/4	1/8	PX23	11/32	17/32	1/4
PX5	1/16	1/4	1/8	PX24	23/64	35/64	1/4
PX6	5/64	1/4	1/8	PX25	3/8	5/8	1/4
PX7	3/32	1/4	1/8	PX26	25/64	5/8	1/4
PX8	7/64	1/4	1/8	PX27	13/32	19/32	1/4
PX9	1/8	1/4	1/8	PX28	27/64	39/64	1/4
PX10	9/64	1/4	1/8	PX29	7/16	5/8	1/4
PX11	5/32	9/32	5/32	PX30	29/64	45/64	1/4
PX12	11/64	11/32	3/16	PX31	15/32	23/32	1/4
PX13	3/16	3/8	3/16	PX32	31/64	3/4	1/4
PX14	13/64	3/8	3/16	PX33	1/2	3/4	1/4
PX15	7/32	13/32	3/16	PX35	17/32	3/4	1/4
PX16	15/64	27/64	3/16	PX37	9/16	13/16	1/4
PX17	1/4	7/16	3/16	PX41	5/8	7/8	1/4
PX18	17/64	7/16	1/4	PX45	11/16	15/16	1/4
PX19	9/32	15/32	1/4	PX49	38/4	1"	1/4
PX20	19/64	1/2	1/4	PX57	7/8	1-1/8	1/4
PX21	5/16	1/2	1/4	PX65	1"	1-1/4	1/4

## PDM Standard Straight Type Ejector Pins

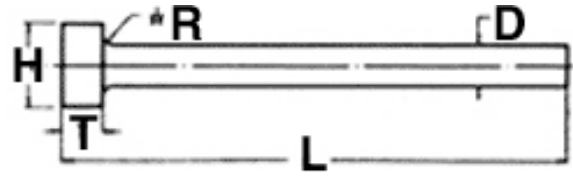

### TOLERANCE

D - PIN DIA.	+ .000 - .001
H - HEAD DIA.	+ .000 - .010
T - HEAD THICK.	+ .000 - .002
L - OVERALL LENGTH	+ 1/32 - .000

NOTE: When ordering, specify Catalog No. and length, or pin diameter and length. Non-Standard sizes available on Request

Long Pins available (over 18") made to order

# PDM Ejector Pins

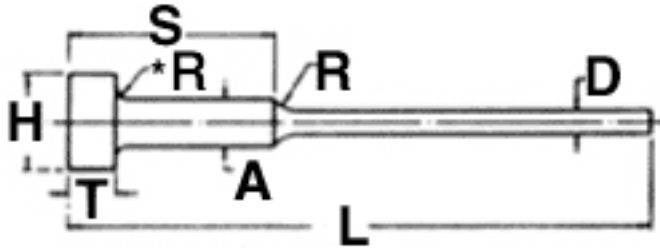

## PDM Standard Step Type Ejector Pins

CAT. NO.	PIN DIA. D	HEAD DIA. H	HEAD THICK. T	SHANK LGTH. S	OVER-ALL LGTH	CAT. NO.	PIN DIA. D	HEAD DIA. H	HEAD THICK. T	SHANK LGTH. S	OVER-ALL LGTH	
MX 1/26-3	1/32	1/4	1/8	<b>1/2</b>	6	MX210-8	7/64	1/4	1/8	2	10	
MX 1/26-4	3/64	1/4	1/8		6	MX 48-3	1/32	1/4	1/8	<b>4</b>	8	
MX 1/26-5	1/16	1/4	1/8		6	MX 48-4	3/64	1/4	1/8		8	
MX 1/26-6	5/64	1/4	1/8		6	MX 48-5	1/16	1/4	1/8		8	
MX 1/26-7	3/32	1/4	1/8		6	MX 48-6	5/64	1/4	1/8		8	
MX 1/26-8	7/64	1/4	1/8		6	MX 48-7	3/32	1/4	1/8	8		
MX 26-3	1/32	1/4	1/8		<b>2</b>	6	MX 48-8	7/64	1/4	1/8	8	
MX 26-4	3/64	1/4	1/8			6	MX 610-4	3/64	1/4	1/8	<b>6</b>	10
MX 26-5	1/16	1/4	1/8	6		MX 610-5	1/16	1/4	1/8	10		
MX 26-6	5/64	1/4	1/8	6		MX 610-6	5/64	1/4	1/8	10		
MX 26-7	3/32	1/4	1/8	6		MX 610-7	3/32	1/4	1/8	10		
MX 26-8	7/64	1/4	1/8	6		MX 610-8	7/64	1/4	1/8	10		
MX 28-3	1/32	1/4	1/8	<b>8</b>		8	MX 812-4	3/64	1/4	1/8		12
MX 28-4	3/64	1/4	1/8			8	MX 812-5	1/16	1/4	1/8	12	
MX 28-5	1/16	1/4	1/8			8	MX 812-6	5/64	1/4	1/8	12	
MX 28-6	5/64	1/4	1/8			8	MX 812-7	3/32	1/4	1/8	12	
MX 28-7	3/32	1/4	1/8			8	MX 812-8	7/64	1/4	1/8	12	
MX 28-8	7/64	1/4	1/8			8	MX 1014-4	3/64	1/4	1/8	<b>10</b>	14
MX 210-4	3/64	1/4	1/8			10	MX 1014-5	1/16	1/4	1/8		14
MX 210-5	1/16	1/4	1/8			10	MX 1014-6	5/64	1/4	1/8		14
MX 210-6	5/64	1/4	1/8	10		MX 1014-7	3/32	1/4	1/8	14		
MX 210-7	3/32	1/4	1/8	10		MX 1014-8	7/64	1/4	1/8	14		

# Custom Order Form

<b>Name:</b>	
<b>Company Name:</b>	
<b>Billing Address:</b>	<b>Shipping Address:</b>
<b>City:</b>	<b>City:</b>
<b>State:</b>	<b>State:</b>
<b>Zip/Postal Code:</b>	<b>Zip/Postal Code:</b>
<b>Day Phone:</b>	<b>Fax Number:</b>
<b>E-Mail:</b>	<b>Date Required by:</b>

## Conventional Ejector Sleeve

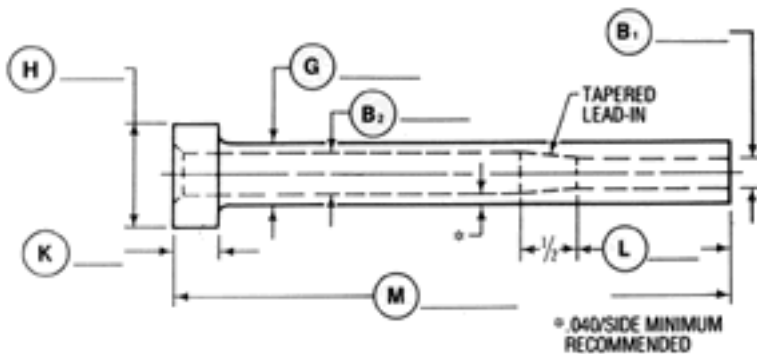

Dimensions	
<b>B1</b>	<b>K</b>
<b>B2</b>	<b>L</b>
<b>G</b>	<b>M</b>
<b>H</b>	

<b>Quantity</b>	
<b>Material</b>	<b>H 13    Other</b>
<b>Other Material</b>	
<b>Hardness</b>	<b>(Rc)</b>
<b>Nitride</b>	<b>O.D.    I.D.</b>
<b>Tolerances*</b>	
<b>Comments</b>	

Ejector Sleeve Tolerances*	
Sleeve/Shoulder Dia.(G/D)	+ .000 - .001
Head Diameter (H)	+ .000 - .010
Head thickness (K)	+ .000 - .002
Sleeve I.D. (B)	+ .0005 - .0000
Length (M)	+ .12 - .00
*Standard tolerances unless otherwise noted	

Fax To: 262-255-3655 or complete On-Line @ our website: [www.performancealloys.net](http://www.performancealloys.net)

# Custom Step Pin

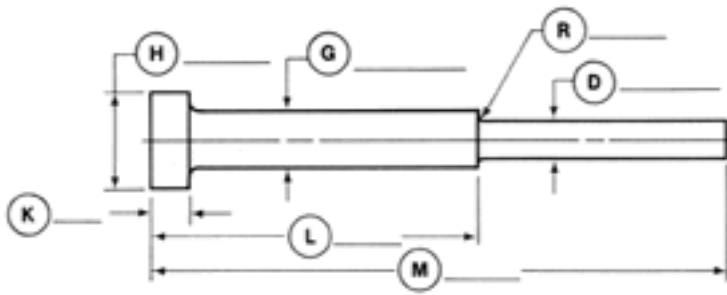

<b>Quantity</b>	
<b>Material</b>	<b>H 13    Other</b>
<b>Other Material</b>	
<b>Hardness</b>	<b>(Rc)</b>
<b>Nitride</b>	<b>Yes    No</b>
<b>Tolerances*</b>	
<b>Comments</b>	

<b>Dimensions</b>	
<b>D</b>	<b>L</b>
<b>G</b>	<b>M</b>
<b>H</b>	<b>R</b>
<b>K</b>	

<b>Core Pin Tolerances*</b>	
Pin Diameter (G)	+ .001 - .000
Head Diameter (H)	+ .000 - .010
Head Thickness (K)	+ .000 - .002
Length (M)	+ .375 - .00
*Standard tolerances unless otherwise noted	

<b>Ejector Pin Tolerances*</b>	
Pin Diameter (G)	+ .000 - .001
Head Diameter (H)	+ .000 - .010
Head Thickness (K)	+ .000 - .002
Length (M)	+ .375 - .00
*Standard tolerances unless otherwise noted	

Fax to: 262-255-3655 or complete these forms Online @ our website:  
[www.performancealloys.net](http://www.performancealloys.net)

# Conventional Pin

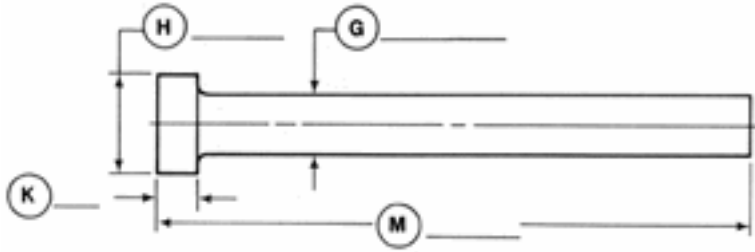

Dimensions	
G	K
H	M

Quantity	
Material	H 13    Other
Other Material	
Hardness	(Rc)
Nitride	Yes    No
Tolerances*	
Comments	

## Order Specifications



## WELDING GUIDELINES for *MoldStar*®150 & *MoldStar*®90

Feedback from material users that have welded *MoldStar*® 150 and *MoldStar*® 90 indicate that Tig welding with Argon as the preferred shielding gas for Tool and Die type welding.

Brazing, gas welding and silver soldering are not recommended and did not show much success or promise.

Small parts do not need to be preheated, other than to warm the part enough to dry them of environmental humidity.

Larger blocks should be preheated to between 400 and 500 degrees F. This procedure is done primarily as a measure to keep the block itself from being a heat sink. If this measure is not taken, the cooler mass of the block will pull heat needed to melt away from the area of concentration.

During preheating procedures, blocks should not be left in room air at elevated temperatures longer than actually needed to elevate to desired temperature. If blocks are left to preheat for excessive periods of time, copper oxides will form on surfaces which is potential contamination to weld area. If oxides form they should be cleaned from the immediate weld area, prior to welding procedure, with a wire brush or other non-destructive cleaning method.

WELDROD: to be used for repair is our *MoldStar*® weld wire.

Available from us in 1/16 diameter x 36" bare wire electrode and also .047 diameter as coil stock both sizes are sold per pound. *MoldStar*® weld rod available Exclusively from Performance Alloys. (Approx 20 pieces of 1/16 wire to the pound)

Our NEW *MoldStar*® weldrod has shown to be the rod of choice to repair all *MoldStar*® alloys, Copper Nickel alloys, and Beryllium Copper alloys. **HARDNESS** level is reasonably close to parent material where applied,

Great **COLOR MATCH** with no sink at edges of weld zone.

Alternate welded materials:

- 420 Stainless, for high hardness
- 17-4PH Stainless, for hardness

Weld Sample Shown below Courtesy of Five Star Tool Welding, Butler, Wisconsin, 262-783-5822,

*MoldStar*® is a registered Trademark of Performance Alloys and Services, Inc.

**Performance Alloys and Services, Inc.**

**1-800-272-3031 or 262-255-6662**

**Fax: 262-255-3655**

**Email: nobecu@aol.com**

# Mold ★ Weld Wire

## NEW FOR WELD REPAIR OF COPPER BASED ALLOYS

For WELDING ALL COPPER ALLOYS USED IN MOLD APPLICATIONS SPECIFICALLY: *MoldStar*® 150, *MoldStar*® 90, C18000, Ampco® 940 & MoldMATE® 90 as well as Brush Wellman's moldMAX® LH & HH, also PROtherm®, and other BeCu alloys.

*MoldStar*® Weld Wire is a **BRAND NEW** product developed by Performance Alloys for use by tool and die/mold welders.

*MoldStar*® Weld Wire is **high purity** and alloyed specifically for repairing or restoring surfaces, edges, corners and areas that have been machined or damaged outside of acceptable limits. This product is **Beryllium-Free** but can be used to weld Beryllium copper alloys, with the same outstanding results as seen when used on *MoldStar* alloys.

- Excellent **Color Match** with both Copper Nickel & Beryllium Copper Alloys
- Hardness **AS APPLIED** is within 2-4 to Rockwell "C" points of Parent Material applied to.
- **Beryllium-Free**
- Available in 1/16 X 36" Bare Wire Electrode & .042 Coil Stock
- Approx. 20 pieces 1/16 per Pound

Please have your TOOL WELDER Contact US for *MoldStar*® Weldwire

Performance Alloys and Services, Inc.  
1-800-272-3031 or 262-255-6662  
Fax: 262-255-3655  
Email: nobecu@aol.com

# Copper Beryllium Vs. Beryllium-Free Copper

Learning the advantages and disadvantages of each alloy coupled with adhering to safety measures can help your shop stay safe.

Sherry L. Baranek

Both copper beryllium and beryllium-free copper producers are vehement and adamant about why their products are better and safer than the others out there — and between MSDSs, newspaper articles and media hype, separating fact and fiction can be a confusing and time-consuming venture. Representatives from both sides of the fence weigh in on the pros and cons of each alloy so you can make the right decision about what is best for your shop.

Beryllium — a silver-gray metallic element that occurs naturally in about 30 minerals — is lighter than aluminum yet stiffer than steel. For the moldmaker, this translates into efficient heat conduction and faster cooling. However, this element can be hazardous to your health. According to the Department of Energy (DOE) Training Reference for Beryllium Workers and Managers/Supervisors Participant Manual entitled *Communicating Health Risks, Working Safely With Beryllium*, the most significant disadvantage of beryllium as an industrial material is the toxicity of its dust, fumes and soluble salts. And, unless ventilation and other controls are used, small particles and chips of insoluble beryllium-containing materials break off during machining and other processes and spread through the air in the work area.

Inhalation of these tiny particles is the type of exposure that can lead to chronic beryllium disease (CBD) — an irreversible and sometimes fatal scarring of the lungs (see *Warning Signs of Chronic Beryllium Disease*). On the other hand, all of the documented cases of CBD thus far have dealt with the element in its pure form — either as pure beryllium or pure beryllium compounds — and once beryllium is dissolved into copper, beryllium comprises about 1.85 percent of the alloy.

Non-beryllium copper alloys — developed as an alternative to copper beryllium — contain nickel, which also is on the same list of hazardous substances. However, non-beryllium alloy manufacturers point out that nickel is only a carcinogen in fish, and when nickel is machined and ground, the particles do not become airborne, as is the case with beryllium.

So, what is a moldmaker to do when confronted with such a difference of opinion on such a controversial topic? Who is right and who is wrong? How can you be sure that the information out there is accurate? Unfortunately, there is not enough evidence at this time to provide you with the “right” answer — but you can take a closer look at both sides of the story to make a more educated decision.

## Copper Beryllium

Nate Gildersleeve, director of technology for NGK Metals Corp. (Reading, PA) — a manufacturer of copper beryllium products — urges people to be cautious when dealing with copper beryllium, but not to panic. “As a rule, anything that is published — particularly by manufacturers of competitive alloys — does not distinguish between handling pure beryllium and something that contains less than one percent of beryllium. People just see that name beryllium and it is dealt with categorically. Even we actually don’t make as much discrimination as is deserved between pure beryllium and a beryllium-containing alloy because we want people to treat it with respect.

“The unfortunate effect — based on what’s been published and what the competitive material manufacturers put out there — is that respect has been replaced by fear,” Gildersleeve continues. “It’s very counterproductive for us. This is the heart of the subject, yet it’s appropriate to keep people grounded in caution — they

## Shop Talk

Recently *MoldMaking Technology* magazine conducted an online poll to discover which alloy was more prevalent in the shop. Forty-three percent of the respondents reported that they use both copper beryllium and beryllium-free copper alloys, 43 percent only use beryllium-free copper alloys, and 14 percent use copper beryllium exclusively.

Copper beryllium alloy users cited better cooling properties and heat transfer qualities as the main reasons that they use these alloys. One respondent felt that “copper beryllium is harder and stands up to the rigors of molding better.” Users of beryllium-free copper alloys noted safety and health concerns over copper beryllium as the reason they choose beryllium free. Several respondents also felt that they achieved the same performance with beryllium-free copper “without the problems.”

shouldn’t grind half of the material away and just let it get into the air because there may be one of those unlucky couple percent of people with ‘right’ allergy that will cause them to contract CBD. We still have to be responsible about it, but we are always looking for an appropriate way to improve people’s understanding about what the risks are and where they come from, and what’s the magnitude compared to what they are reading about. It’s hard to separate from all of this when the word beryllium is in your name.”

Carlos Cruz Wilson, a metals specialist for Houston, TX-based National Bronze and Metals, Inc. — a producer and distributor of a range of copper and copper alloys in various forms and shapes — also feels

the public outcry over copper beryllium is mainly caused by ignorance. “The health issues, although legitimate, can be controlled with the proper handling of the beryllium alloys, or even the beryllium metal itself,” he states. “Only when beryllium-containing materials are ground, sanded, polished, welded, EDM’d or changed — producing a dust, fume or mist — will there be any risk of exposure. Turning, milling and drilling presently create no risk when done wet with the proper coolant.

“Only when these airborne particles are less than 10 microns in diameter are they able to penetrate the air sacs of the lungs, thus causing a high risk situation,” Wilson continues. “For beryllium to cause disease, the particles must penetrate the air sacs of the lungs with repeated exposure. The person exposed also needs to be allergic to beryllium to get the disease, and statistics show that only about three to four percent of the population is susceptible to the effects of beryllium.”

Wilson adds that beryllium’s unique properties “give copper the strength of steel, with the conductivity of a copper alloy,” and allow the moldmaker to bring heat energy into the old and dissipate that energy very quickly. “The results are shorter cycle times, which leads to the ability to produce more parts and put more money in your pocket,” he affirms.

NGK Metals mandates that first-time buyers of its copper beryllium read the MSDSs and *Speaking Out* literature that describe the risks of working with the alloy and how these risks are managed. “In a nutshell, if you are set up to safely machine metals, you also can safely machine beryllium copper,” Gildersleeve states. “There isn’t a lot of dry grinding that goes on out there for making a finished machine part, or the kinds of operations that put fine particles into the air. We do caution moldmakers against torch cutting pieces — to cut into larger pieces they should be using a saw. We make precautionary statements and we are liable and required to put some very stringent warning labels on the material as well to protect against misuse.

“The non equitable facet to this that’s always amazed me is that there have been arguments for some time about how to characterize the health hazards of beryllium and what levels are appropriate and so forth; and most of the competitive alloys contain nickel — which has been a known carcinogen for a long time — and there’s just no fuss made about that for some reason,” Gildersleeve adds. “I mean,

## Warning Signs of Chronic Beryllium Disease (CBD)



CBD is primarily a lung disease, although it can affect other organs — like the lymph nodes, skin, spleen, liver, kidneys and heart. It occurs in individuals who are “allergic” or sensitized to beryllium upon exposure. The long-term health effects can take years to develop after the first exposure to beryllium and there have been cases where people who were exposed to very small amounts of beryllium contracted CBD.

Symptoms of CBD may include the following:

- ➔ Persistent coughing.
- ➔ Fatigue.
- ➔ Shortness of breath with physical exertion.
- ➔ Blood in saliva and mucus that is coughed up.
- ➔ Chest and joint pain.
- ➔ Loss of appetite.
- ➔ Rapid heart rate.
- ➔ Fevers and night sweats.

If you are experiencing any of these symptoms contact your physician.

— *From Communicating Health Risks, Working Safely With Beryllium (published by DOE).*

it’s in your flatware, stainless steel, etc., and the copper alloys that compete with beryllium copper contain higher levels of nickel, but for whatever reason it just doesn’t seem to get much attention.”

Cliff Moberg, president of Performance Alloys (Germantown, WI) — a supplier of beryllium-free copper alloys for use in constructing cavities, cores and inserts, as well as other applications — refutes the aforementioned statement. “While nickel is a listed carcinogen, the human exposure methods vastly differ for the elements beryllium and nickel,” he explains. “The risk to humans with nickel is through ingestion of contaminated fish and seafood caught from nickel-contaminated waters. Those contamination arenas were common in the days of industrial waste dumping prevalent in years past. Additionally, since nickel is a heavy metal, the particles do not become airborne like beryllium,” he points out, “and there is no known direct connection to human disease with inhalation of nickel, where there is with beryllium.”

### Beryllium-Free Copper

According to Moberg, his company’s copper nickel alloys possess the same

superior strength and conductivity of copper beryllium, if not better. “In addition, we have found that copper beryllium products are sensitive to heat,” he comments. “In other words, some copper beryllium alloys lose hardness, tensile and conductivity if it is heated above 600°F, where our product is unaffected to temperatures in excess of 900°F.”

Moberg also contends that copper beryllium producers use a number of tactics to steer potential users toward their product and mask the alloy’s contents that could be termed questionable. “The most obvious example is that they publish copper beryllium’s ultimate properties instead of the average numbers to compare their products,” he says. “Our competitors publish their numbers on a higher scale while we publish our nominal numbers — taking their very best properties and publishing them instead of publishing the typical mean (most often attainable) numbers that we do. It would be nice if they would note that they were publishing their ultimate properties. We note in our literature that our numbers are nominal. If you are comparing products, make sure that the information you are looking at is either third-party based or it’s objective

reporting — not something provided from the producer of the product.”

To that statement NGK Metals’ Gildersleeve responds, “Among beryllium copper producers, there may be some variations in how the product is presented in promotional literature,” he comments. “It appears to me that beryllium copper products are represented nominally, rather than the highest possibility, including promotions published by our direct competition (i.e., beryllium copper producers). For instance, a possible hardness range for one product may be 36 to 42. The median is 39, but the product may be nominally advertised at 40. I do not cry foul against our competitor because their product (and ours) is statistically better represented by 40 than by 38 or 42 after testing hundreds of pieces.”

Moberg of Performance Alloys adds that recent independent testing conducted at Western Michigan University proves that beryllium-free alloys perform from a cycle time standpoint about five to seven percent better than any of the beryllium copper

alloys that were tested. According to this study — which compared widely used mold steels with beryllium copper and beryllium-free copper alloys and focused on cycle time reduction, quality changes and component performance — the beryllium-free alloy performed seven percent faster than the beryllium copper alloys.

### **Making a Choice**

NGK Metals’ Gildersleeve does his best to simplify this complicated issue. “It really boils down to whether the part manufacturer is designing the tool, or a machine shop or subcontractor is designing the tool,” he states. “If your job is to make money by making more parts that you can ship at the end of the day, then beryllium copper will give you a way to do that. That is our experience. When we see people designing molds whose primary source of revenue comes from making parts, there’s beryllium copper all over their molds. If their primary source of revenue is making molds, beryllium copper is usually

relegated to occasional insert materials where just nothing else will work.”

As the popular saying goes, “Forewarned is forearmed.” Before you make a decision about which alloy to use, educate yourself. Your alloy manufacturers and suppliers have guidelines for safe machining, EDM’ing and polishing. Go to their websites and read the MSDSs. The information is out there and readily available — it is up to you to get your hands on it and absorb it before you can decide what works for your shop. Gildersleeve sums it up quite nicely, “Whether you are using a beryllium-containing alloy or a non-beryllium-containing alloy, don’t use either as a license to lower your guard about health and hygiene.”

---

MMT

*For more information contact **Carlos Cruz Wilson** of National Bronze & Metals, Inc. (Houston, TX) at (713) 869-9600, **Nate Gildersleeve** of NGK Metals Corp. (Reading, PA) at (610) 921-5026 and **Cliff Moberg** of Performance Alloys (German-town, WI) at (262) 255-6662.*

---

©2002 Communication Technologies, Inc., All Rights Reserved.

Reprinted from *MoldMaking Technology* magazine. Contents cannot be reprinted without permission from the publisher.

[www.moldmakingtechnology.com](http://www.moldmakingtechnology.com)